



**MATERIAL  
HANDLING**

**INDUSTRIAL  
BLOWER**

**DUST  
COLLECTORS**

**WEIGHING  
&  
BAGGING**



*DIYANI Engineering presents, **Hexagon** The leading brand has been in business of Material Handling of Raw materials, Industrial Blowers and Dust collectors, Company is Constantly looking at the way we operate in order to stand out from our competition, our management team is completely focused on technological investment and continuous improvement with tagline of*

***“ Customized Innovation”***

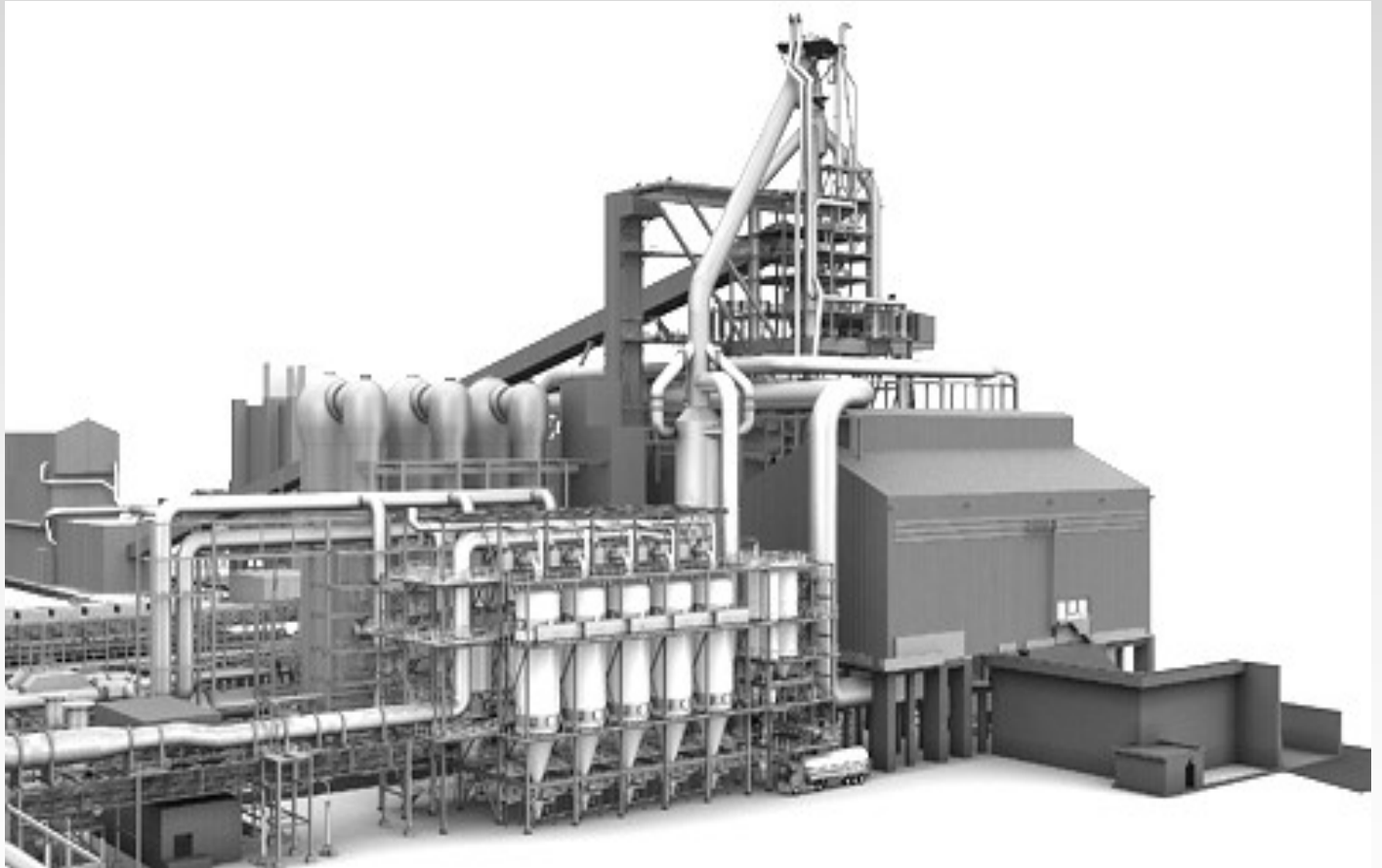

***Imaginations to Implementation***



# INDUSTRIAL BLOWERS

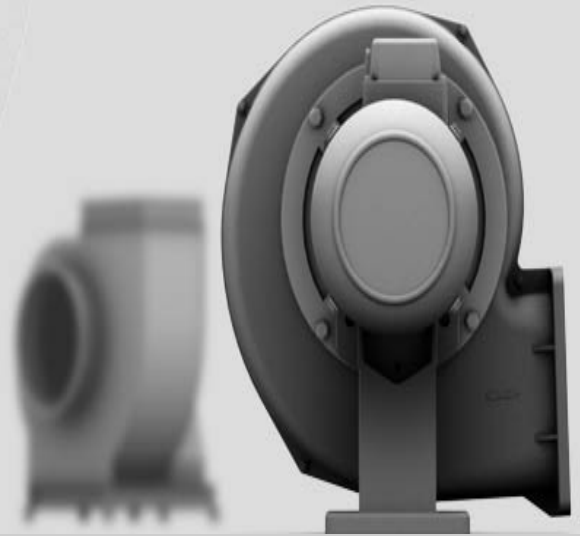

## INDUSTRY WE SERVE

- ⇒ Boiler & Furnace
- ⇒ Chemical
- ⇒ Pharma
- ⇒ Ceramic
- ⇒ Fertilizers
- ⇒ Sugar
- ⇒ Textiles
- ⇒ Polymers
- ⇒ Petro-chemicals
- ⇒ Cement
- ⇒ Agro & food
- ⇒ Plastic

# Centrifugal



ID FAN

FD FAN

SA FAN

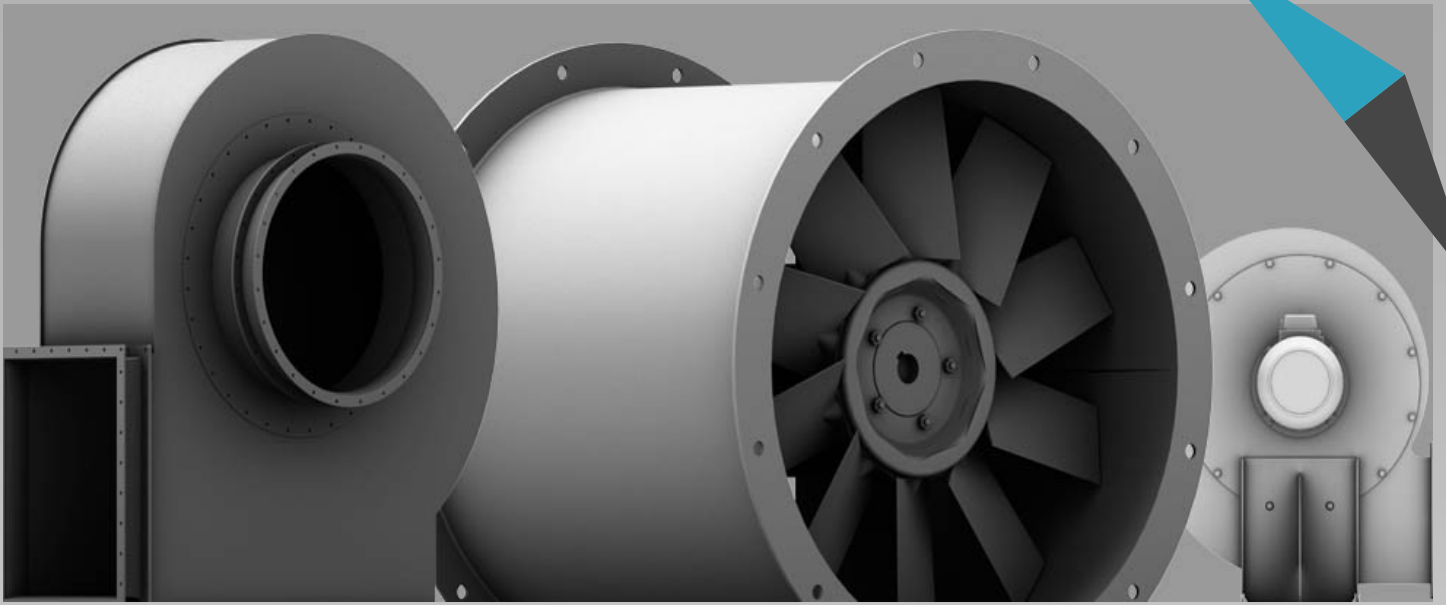

# Dust Collectors & Fans

- ⇒ Cyclone Type
- ⇒ Bag Filter
- ⇒ Portable Dust Collector
- ⇒ Exhaust Fan
- ⇒ Tube Axial

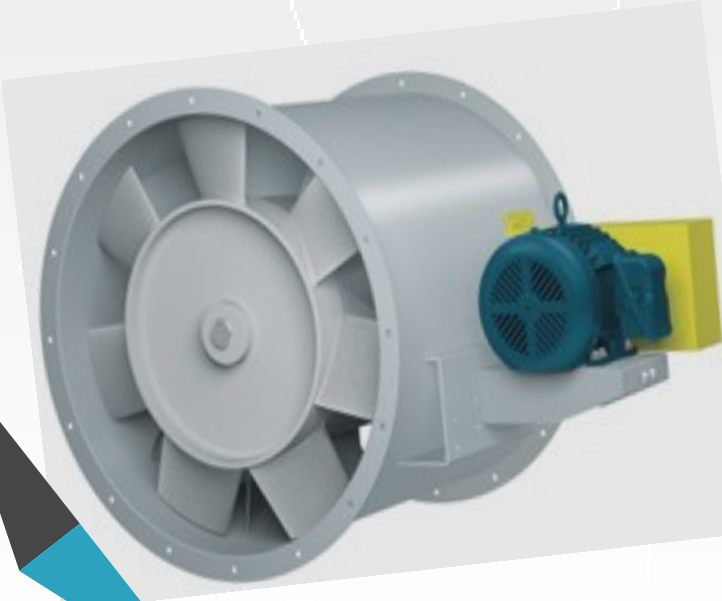
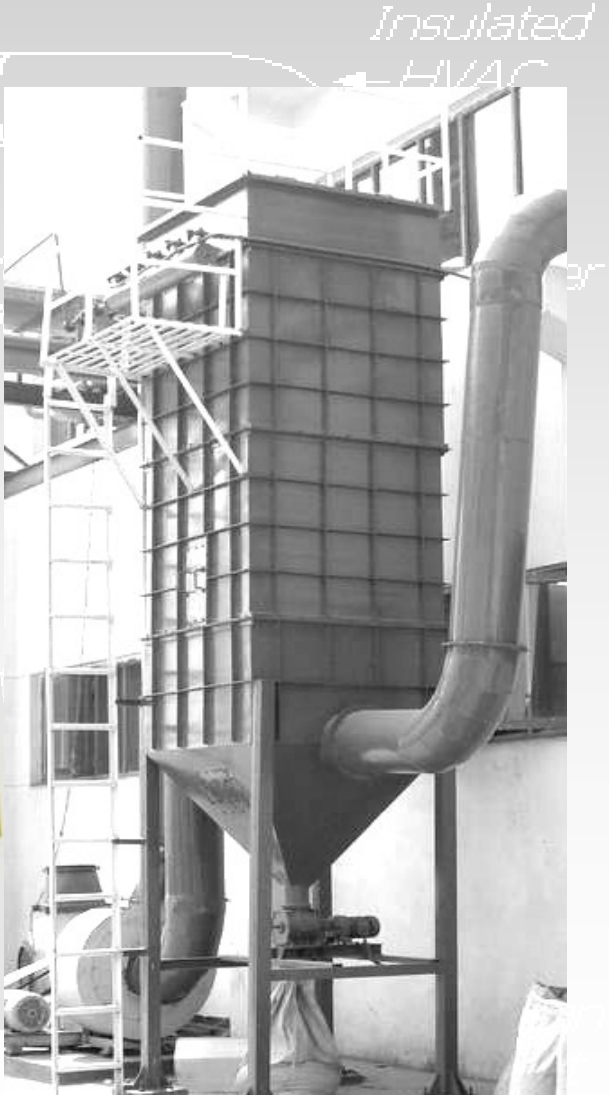

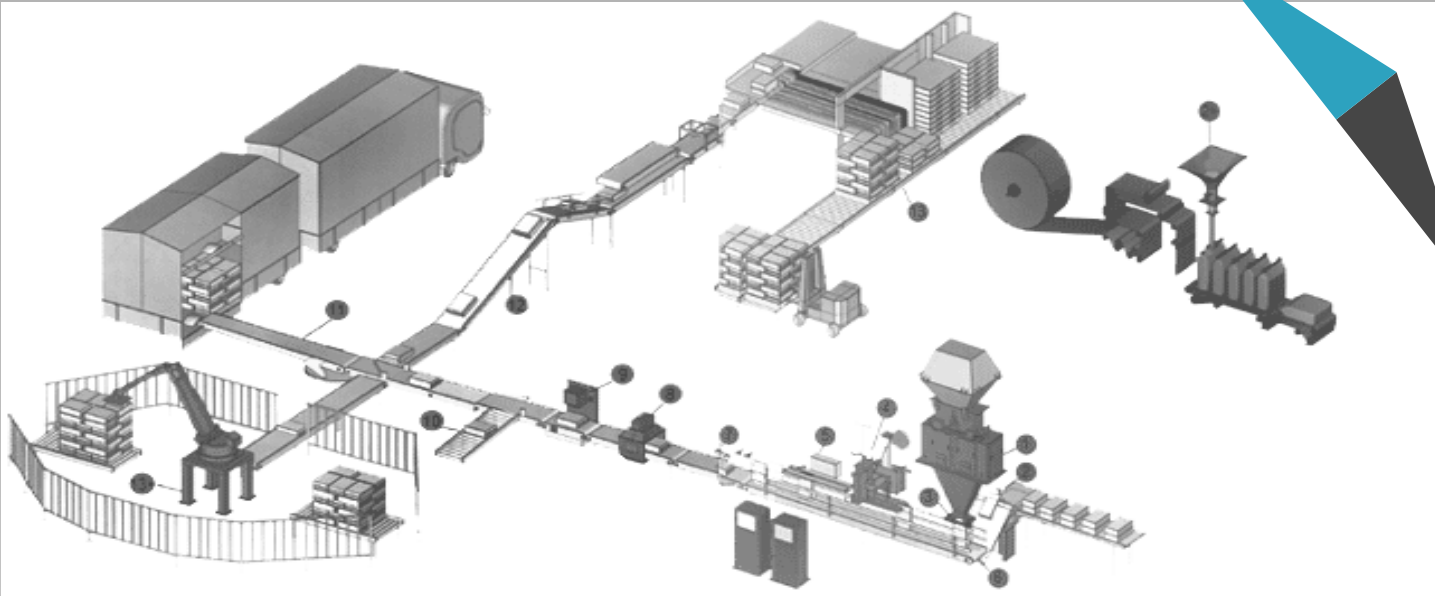

# Weighing & Bagging

- ⇒ *Nett , Gross*
- ⇒ *Jumbo Bagging*
- ⇒ *Liquid Filling*
- ⇒ *5 kg to 2000 kg*
- ⇒ *Batch Weighing*
- ⇒ *Automation*

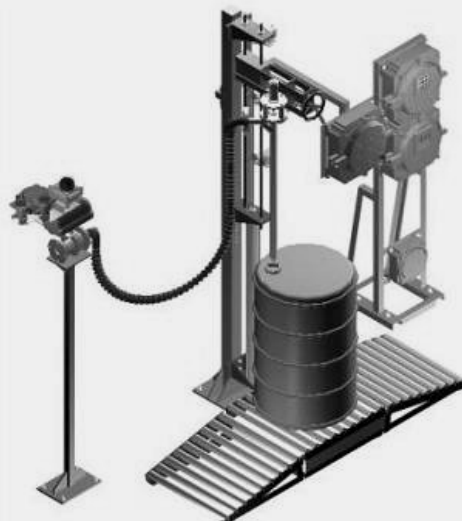
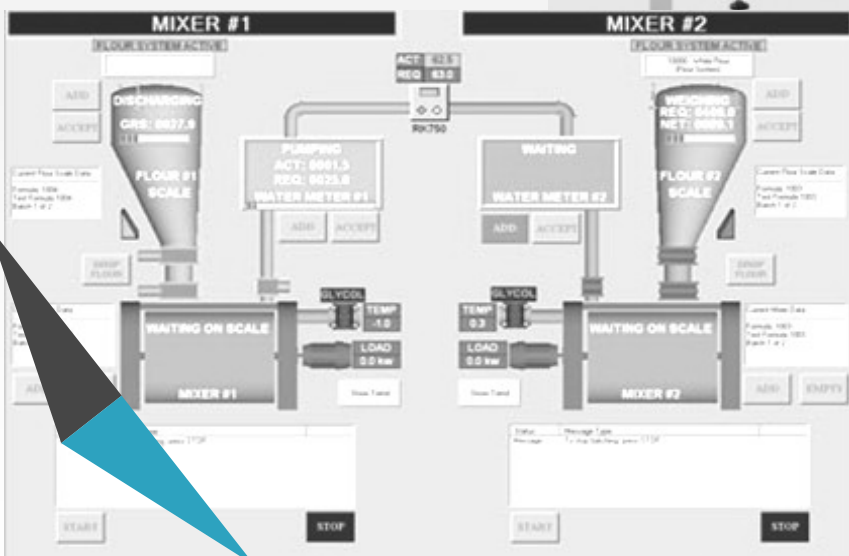
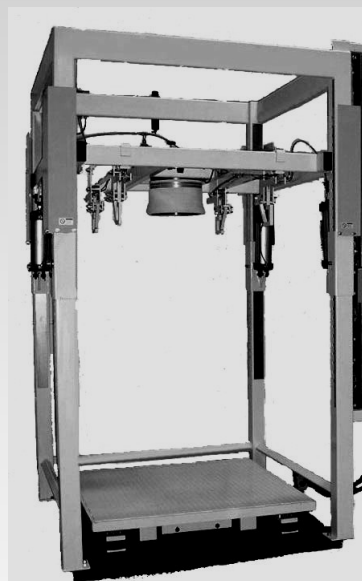

# Material Handling

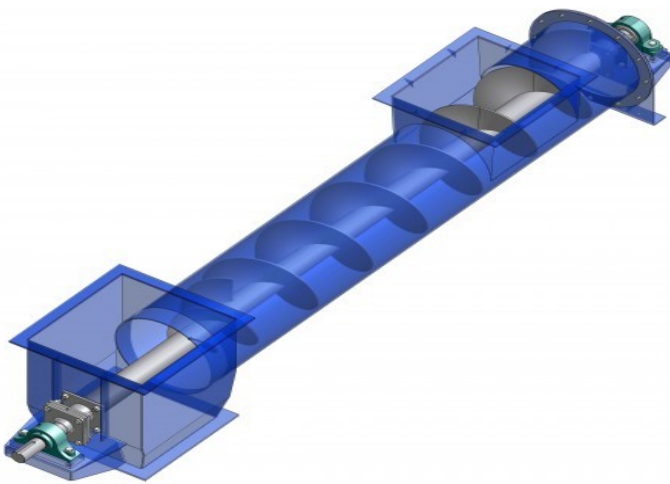
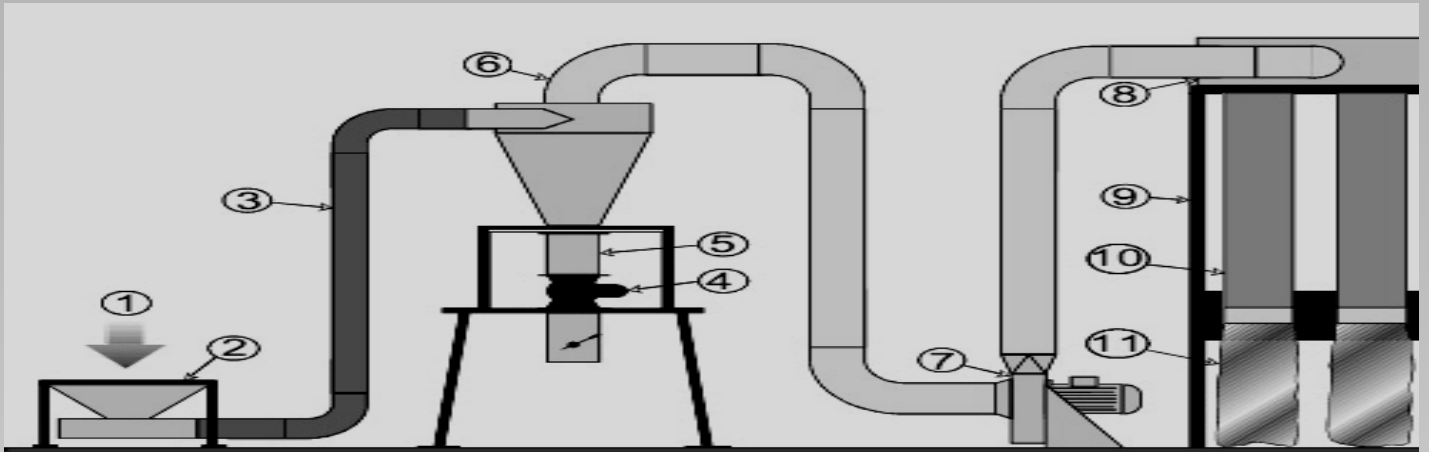

✉ CONTACT US



**DIYANI ENGINEERING**

1 & 2, ANNAPURNA IND. ESTATE, GIDC,

KATHWADA—AHMEDABAD

PHONE—93274 80120

sales@diyani.in

Www.diyani.in